

**Tech-Trak®**

Conveyors for  
Automation



# Conveyors



**Integrated Factory Automation Solutions**  
**Enhancing Productivity and Capital Asset Performance**



## From Integration Design to Quick Deployment

**Tech-Trak® conveyors have a 20-year long and demonstrated reputation as “The System That Works.”**



The Tech-Trak® Series 1700 and 2500 conveyors are single rail palletized conveyors. They are designed to provide a highly effective and flexible factory automation solution for parts up to 250 lbs. at the best cost of total ownership (acquisition, installation, maintenance, and modification cost).

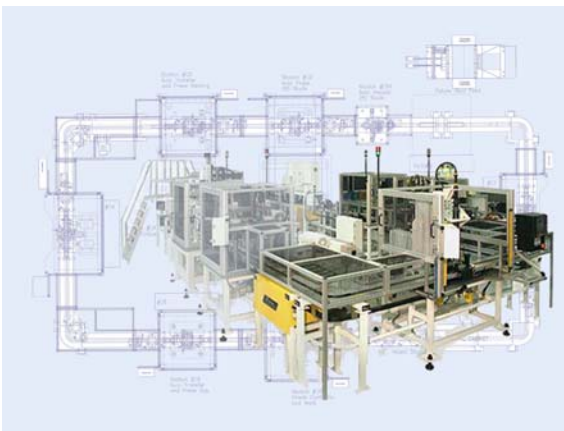

The combination of flexibility and total cost of ownership has over the years led to a very large installed base of Tech-Trak® across a wide range of applications in multiple industries.

Tech-Trak® conveyors have a solid demonstrated performance track record. They have demonstrated the highest uptime in their category.



## All the Benefits You Would Expect From a Leading Conveyor System

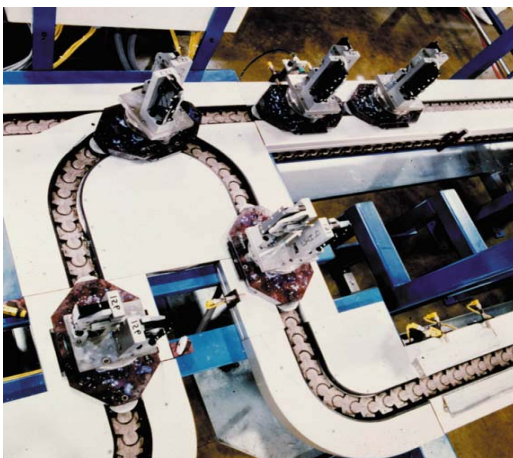

Precision Positioning  
Capability

High Productivity

Easy to Install, Reconfigure,  
and Re-deploy

Easy to Integrate With Other  
Systems and Equipment

Low Operating Cost

Low Maintenance Cost

Minimum Inventory of Spare  
Parts

Highest Production Uptime



# Configuration Solutions

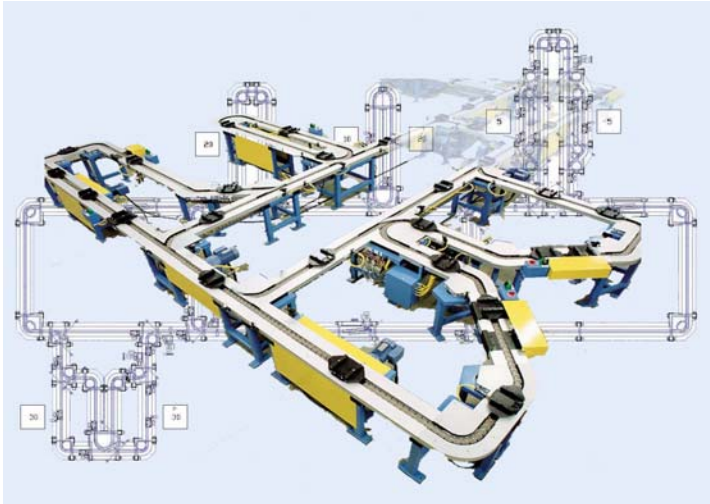

## Highly Configurable and Modular Design

Tech-Trak® modularity allows for the design of any configuration required to accommodate any process while making efficient use of space requirements.

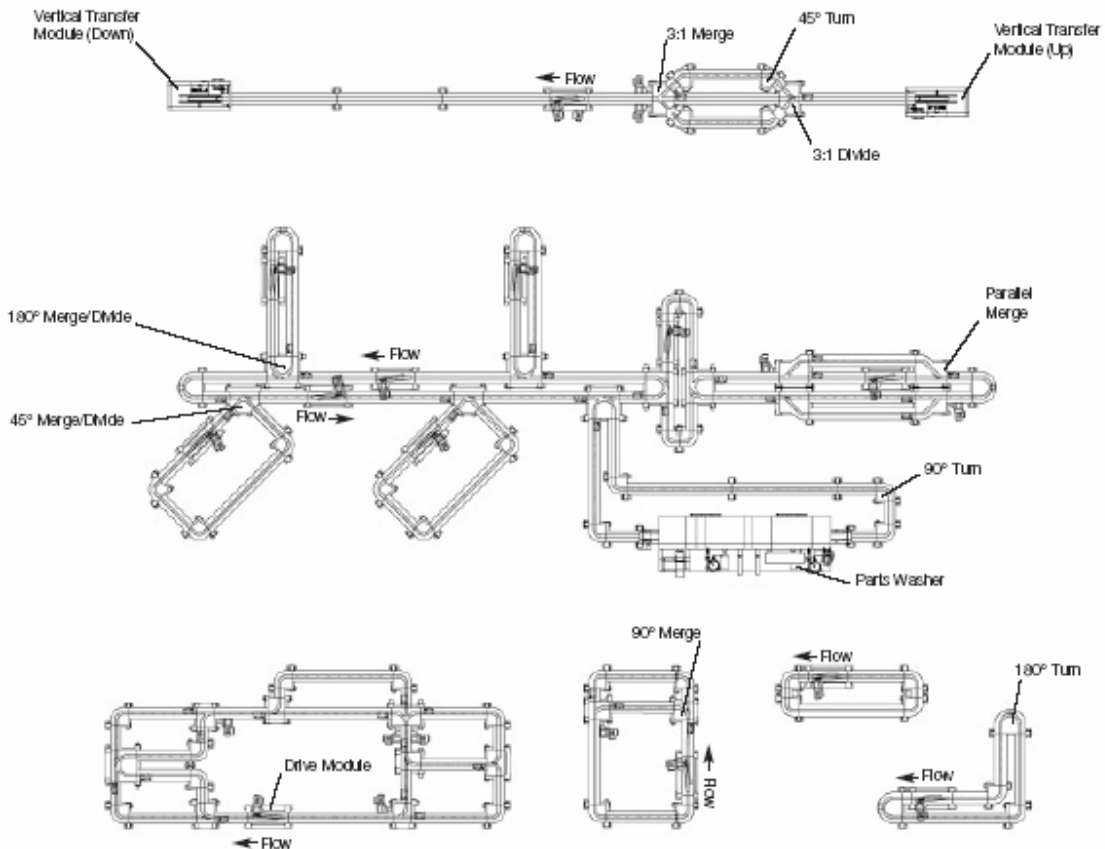



# Modules

**Complete Set of  
Modules To Your  
Requirements**



*For Convenience Refer to Tech-Trak® Catalog  
for Selection and Configuration Assistance*

1. Drive Assembly



2. Chain



3. Straight Track



4. Stops

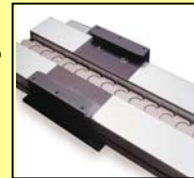

5. Curves



6. Switches



7. Pallets



## Curve and Switch Module Assemblies

A. Support Frame



B. Return Curve

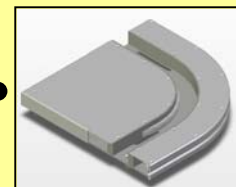

C. Return (chain) Cover



D. Drip Pan



## Applications

The Tech-Trak® Series 1700 and 2500 conveyors provide a modular and flexible way to create platforms for any number of factory automation solutions. Such platforms are typically used for multiple applications and operations integration.



Assembly Systems

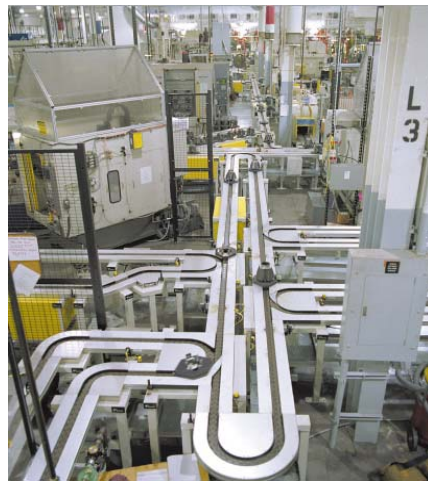

Machine Tool Automation and Interlinking

### Multiple Applications

- ✓ Material handling
- ✓ Assembly
- ✓ Manufacturing
- ✓ Machine Tool Loading
- ✓ Machine Tool Automation and Interlinking
- ✓ Functional Testing

### Integration of Multiple Operations

- ✓ Assembling
- ✓ Machining
- ✓ Washing
- ✓ Marking
- ✓ Testing
- ✓ Calibration
- ✓ Deburring
- ✓ Inspection



Machine Loading



Machine Loading



Material Handling



Robotic Machine Loading Applications



Gantry Loading



## Pallets

Tech-Trak® can accommodate a very wide range of pallets for holding parts and ensuring high precision movement and positioning accuracy.

- ❑ **Standard Size Pallets**
- ❑ **Custom Pallet Designs**
- ❑ **Fixture Designs**



Pallets are application-specific, designed for the specific part.

Pre-engineered pallets offer the economical advantage of a standard pallet carrier requiring minimal customization.

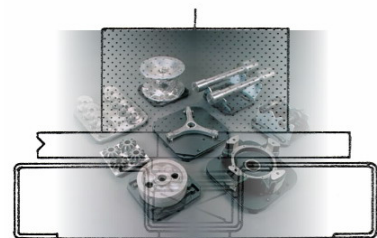
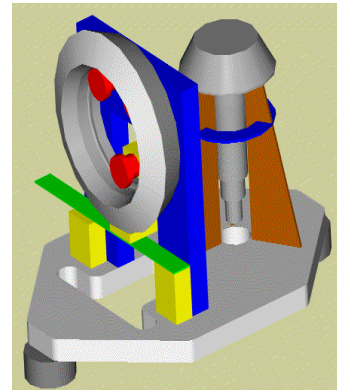

STANDARD PALLET  
CARRIER



**Tech-Trak®**  
*There Is No Limit*

- ✓ Proven
- ✓ Modular
- ✓ Flexible
- ✓ Simple
- ✓ Economical

*The Ultimate Solution  
for Top Performance*

- ✓ Highest Return  
on Invested  
Capital
- ✓ Best Value to  
Total  
Ownership Cost



*Designed For Today Engineered For Tomorrow*



Copyright 2006 Wes-Tech Automation Solutions. All Rights Reserved.